



a *FLODRAULIC* company

# SACE



**PERFORMANCE  
POWER AND CONTROL**



#### **Warehouse**

A wide assortment of hydraulic components from the Danfoss group and the best manufacturers in order to guarantee quality and quick deliveries.



#### **Design**

Our design skills, the integration of electronic know-how, the presence of technical personnel and the selection of the best components on the market allow SACE to provide optimised and extremely reliable solutions.



#### **Assistance**

With the skills and training of our technical personnel, SACE is called upon daily to solve all types of technical problems. We work on site or remotely.



#### **Consultancy**

We meet the needs of our customers, taking care of every single detail and providing the best solution in terms of cost and performance.



#### **Danfoss Authorized Service Center**

In 2019 SACE becomes the first **Danfoss Authorized Service Center** in Italy.

This means not only repairs of all kind of hydraulic components but also handle of warranty claims independently according to Danfoss standards.



#### **E-commerce**

SACE products are also available online. Do-it-yourself: fast, easy and secure.

[sace-srl.com/shop](http://sace-srl.com/shop)

a **FLODRAULIC** company

# **SACE**

#### **SACE, a Danfoss Appointed Sales and Service Partner since 1995,**

works in the hydraulic systems sector as a systems integrator for mobile applications in Italy and Europe. Since 2017, we are part of the Flodraulic group, expanding our areas of application and the variety of our solutions.

Our in-depth applied knowledge and the availability of a wide assortment of components in our warehouse make us an ideal partner to help you rise to important challenges.

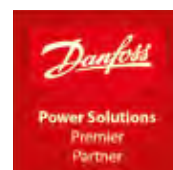



## INDUSTRIES

**AGRICULTURE**

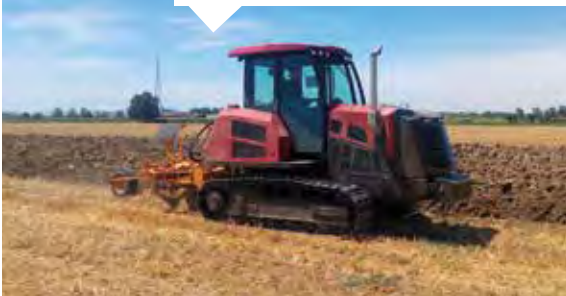

**CONSTRUCTION**



**RAILWAY**



**LIFTING**



**DRILLING**



**MUNICIPALITY**



Through SACE, Oleobi and PK, the Flodraulic group is also able to design integrated solutions for the industrial sector on applications such as offshore, oil & gas, naval, drilling, tunnelling, funfair attractions, hydraulic presses, plastic and metal processing, marine cranes, recycling etc.



## Dedicated software development

Over time, **SACE** has developed skills in electronic integration projects within hydraulic systems.

The software development process is rooted in five fundamental phases:

- **analysis:** gathering of the requirements that the software must meet;
- **design:** definition of the technical specifications that the designers must follow during the build phase;
- **building:** development process including the classic programming phases (encoding, assembly and compilation);
- **testing:** phase during which the parts of the software are assembled and tested together in order to verify that what has been built meets the exact requirements gathered during the analysis phase;
- **release:** final operation in which the program is published and therefore is ready to be installed on the machine.

**SACE** uses the Danfoss Plus+1® as the standard electronic components for solution development, thereby guaranteeing an extremely reliable and high quality final product. The team is also able to work on other types of solutions at the customer's request in order to maintain maximum integration of the systems installed on board the machine.

## Flexible and integrated solutions

We follow our customers through all the phases, from design to start-up of the systems, all the way to post-sale operations, managing every single request down to the tiniest detail. By using technologically advanced tools, we are able to check the real operating parameters of our systems such as pressures, temperatures and capacities, providing the customer with a detailed report on system operation. Our technical office carries out the 2D and 3D design based on the requested technical specifications, guaranteeing quality and flexibility even for subsequent development, changes and, wherever necessary, providing an analysis and FEA simulation along with the design.

We also design and build:

- integrated manifolds complete with hydrological elements and control valves using the materials required by the specific applications (aluminium, cast iron, steel and stainless steel) for the purpose of reducing costs and improving functionality;
- special hydraulic cylinders such as plungers, single or double-action, telescopic, with synchronous operation, with constant speed extension, etc.

We can provide the specific certifications (for the product, for the process, for the construction regulations/materials used) required for the applications both in the mobile and the industrial sectors.



a FLODRAULIC company  
**SACE**

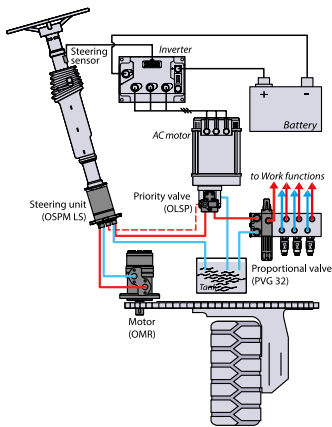

**Work functions and steering**

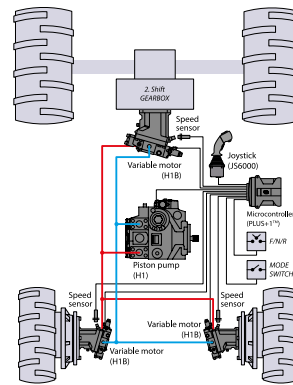

**Propel**

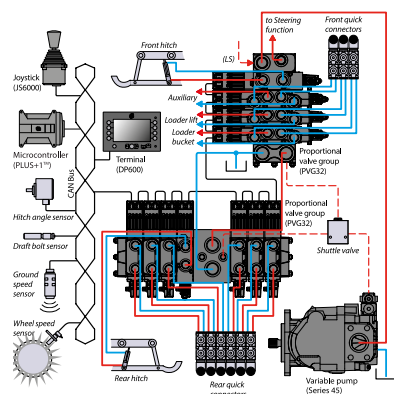

**Work functions**

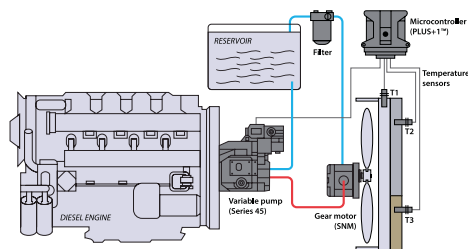

**Fan Drive**

**SACE Srl a Socio Unico**  
Via Cartiera, 154 - 40037  
Borgonuovo di Sasso Marconi (BO) - Italy  
Tel: +39 051 6781120  
Fax: +39 051 6781150  
info@sace-srl.com

[www.sace-srl.com](http://www.sace-srl.com)



Web Shop



**FD FLODRAULIC**